



DEFINITY[®] Communications
System Generic 2

and System 85
**8102 and 8110 Telephone
User's Guide**

NOTICE

While reasonable efforts were made to ensure that the information in this document was complete and accurate at the time of printing, AT&T can assume no responsibility for any errors. Changes or corrections to the information contained in this document may be incorporated into future issues.

TO ORDER COPIES OF THIS DOCUMENT

Contact: AT&T Customer Information Center
2855 North Franklin Road
P. O. Box 19901
Indianapolis, IN 46219
1-800-432-6600,
In Canada: 1-800-255-1242

Order: Document No. 555-104-746
Issue 1, May 1991

For more information about AT&T documents, see *Business Communications Systems Publications Catalog* (555-00-010).

HEARING AID COMPATIBILITY

This equipment is compatible with the inductively coupled hearing aids prescribed by the Federal Communication Commission (FCC).

**Prepared by
AT&T Technical Publications Department
Denver, CO 80234**

**©1991 AT&T
All Rights Reserved
Printed in USA**

Your 8102 and 8110 Telephones

The 8102 and 8110 telephones are similar in appearance; however, the 8110 telephone has an added built-in speakerphone. (If you have an 8110 telephone, you may also be able to use the Auto Answer feature.) Both telephones are designed to help you use the many features the the AT&T DEFINITY® Communications System Generic 2 and System 85.

Check which of these two telephones you are using. Then, familiarize yourself with your telephone by looking carefully at either Figures 1 and 2, the 8102 telephone, or Figures 3 and 4, the 8110 telephone, and reading the explanations of the telephones' many features below the figures

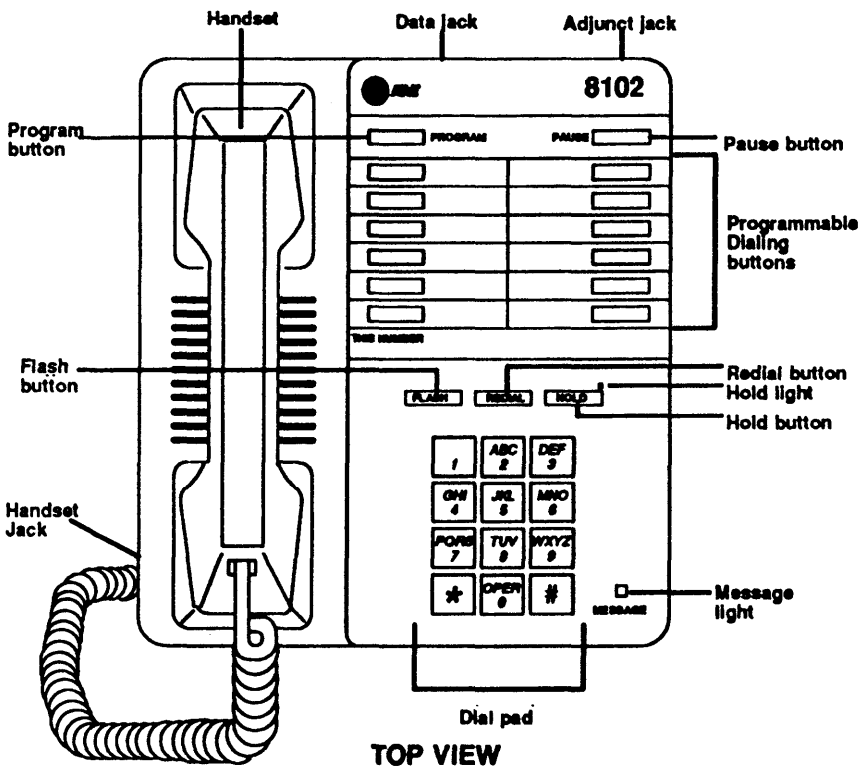

Figure 1. 8102 Telephone, Top View

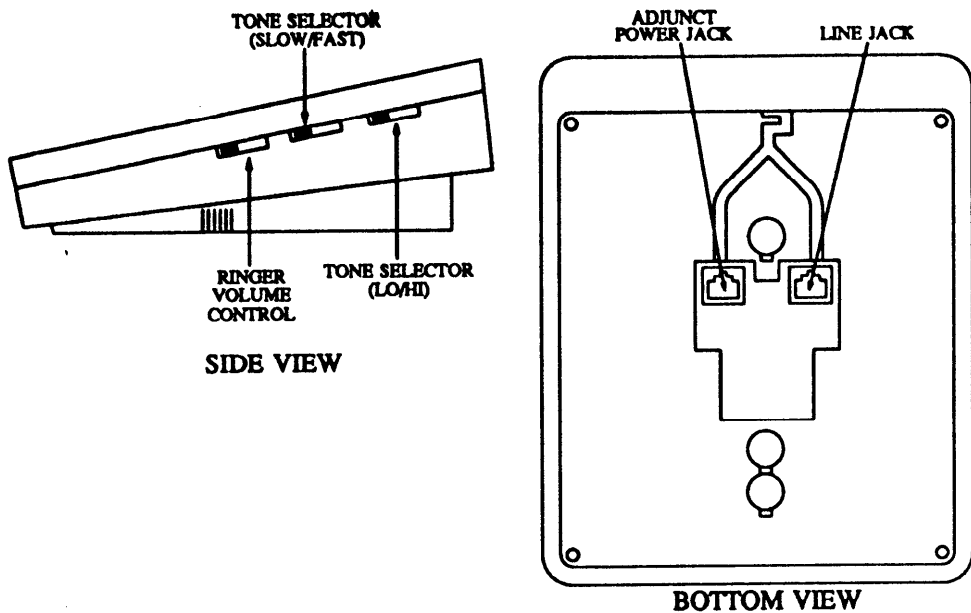

Figure 2. 8102 Telephone, Side and Bottom Views

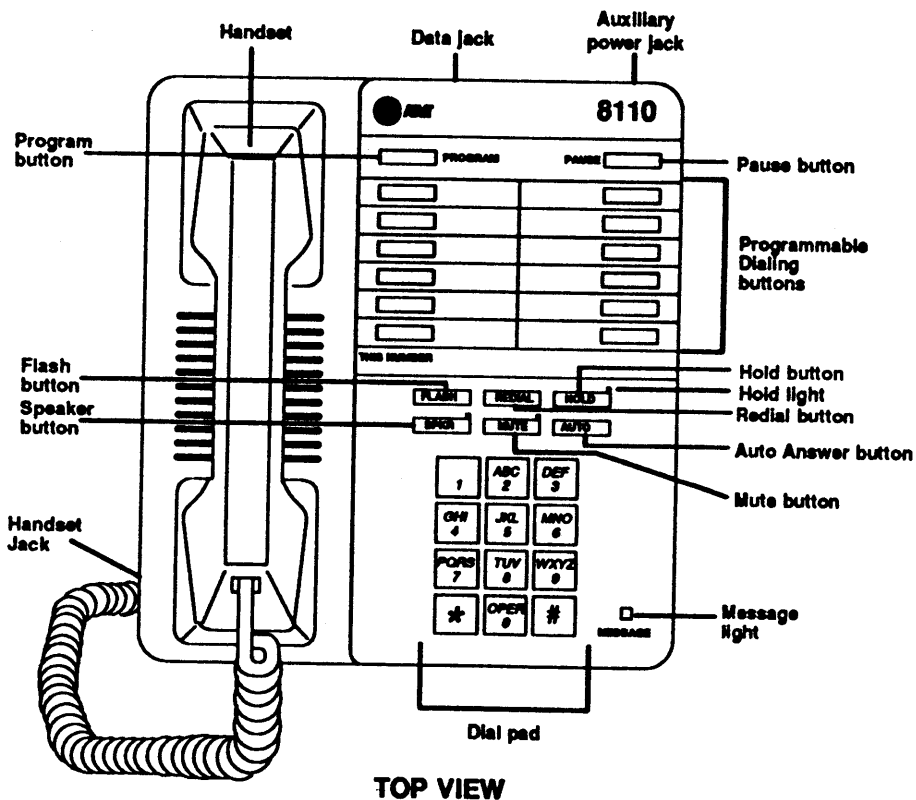

Figure 3. 8110 Telephone, Top View

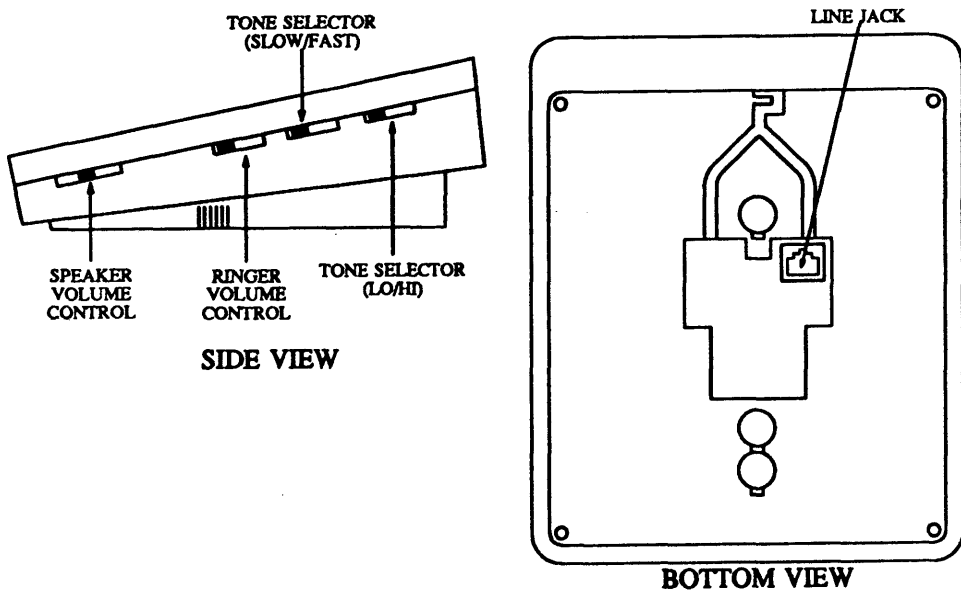
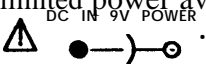



Figure 4. 8110 Telephone, Side and Bottom Views

Starting with the handset on the TOP VIEW and continuing clockwise

- Handset** For placing and answering calls. In most cases, you must lift the handset (go off-hook) before you can use a feature. Also known as the receiver.
- Data jack** For connecting a device such as a modem to your telephone. This jack is labeled DATA.
- Adjunct (equipment) jack (on the 8102 only)** For connecting adjunct equipment such as a speakerphone or headset to your telephone. This jack is labeled ADJUNCT.
- Auxiliary power jack (on the 8110 only)** For improving the performance of the built-in speakerphone on long loops where there is limited power available from the line. This jack is labeled .
- Pause button** For inserting a 5-second pause/delay into a telephone number stored on a programmable dialing button or into a dialing access code in the Auto Pause feature of Redial.
- Programmable Dialing buttons** The 12 buttons on which you can program frequently dialed telephone numbers, emergency numbers, or feature access codes.
- Hold light** A red light that goes on to remind you that you have a call on hold.

Hold button	For putting a call on hold.
Redial button	For redialing the last number you dialed.
Auto Answer button (on the 8110 only)	For automatically activating the built-in speakerphone whenever a call comes in.
Mute button (on the 8110 only)	For turning off the microphone associated with the handset <i>or</i> the built-in speakerphone.
Message light	For indicating when a message has been left for you (slowly flashing red light).
Dial pad	For dialing telephone numbers and accessing features (12-button pad). The dial pad is also used with [PROGRAM] to store numbers on the Programmable Dialing buttons or to store dialing access codes in the Auto-Pause feature of Redial.
Speaker button (on the 8110 only)	For accessing the built-in speakerphone and microphone combination.
Flash button	For using features such as Conference with business communications systems, and for custom calling features if you are using your telephone at home.
Program button	For storing telephone numbers on the programmable dialing buttons on the front of your telephone and dialing access codes in the Auto-Pause feature of Redial.

The SIDE VIEW shows the following features

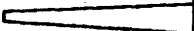
Tone Selector (HI or LO)	For selecting one of two tone ringer frequencies (high or low)
Tone Selector (FAST or SLOW)	For selecting one of two tone ringer modulation rates (fast or slow).
Ringer Volume control	A 3-position switch to control the volume for the tone ringer. Slide it up (away from you) for a louder ring, down (toward you) for a quieter ring. The volume control is labeled Ringer Vol 
Speaker volume control (on the 8110 only)	For raising or lowering the volume of the built-in speakerphone. The volume control is labeled Speakerphone Vol 

The BOTTOM VIEW, for both types of telephones, includes the line jack and, on the 8102 telephone, the adjunct power jack.

Adjunct power jack (for adjunct equipment on the 8102 only)	For connecting an auxiliary power source for using adjunct equipment. This jack is labeled POWER.
Line jack	For connecting a line cord to your telephone. This jack is labeled LINE.

A Quick Look at the Features

The following lists voice features and briefly explains what each one does and how you might want to use it.

The features in this guide have been divided into 2 categories:

- **Phone Features** Those telephone features that you can use immediately *no matter which communications system* your telephone is connected to. **Note:** You can use the Speakerphone and Mute features only if you are using the 8110 telephone. You may also be able to use the Auto Answer feature *if it is assigned* to your 8110 telephone.
- **Switch Features** Those features that you can use *only* with a DEFINITY Generic 2 or System 85 switching system. Most of these features must be assigned by the System Manager to your telephone. Check with your System Manager to see which of these features you can use.

Phone Features

Auto Answer (for 8110 Users) Automatically turns on the built-in speakerphone when a call comes in. Answer calls without lifting the handset and disconnects the call when the calling party hangs up.

Hold Puts a call on hold until you can return to it. While a call is on hold, you can leave your telephone to perform another task. Use when you have a call that you don't wish to drop, but which you have to interrupt briefly to do something else.

Redial (with Auto-Pause) Automatically redials the last number you dialed from the dial pad, either an extension or an outside number. Use to save time in redialing a busy or unanswered number.

Message Your Message light lets you know that a caller has left a message for you. You can then follow your System Manager's local message retrieval procedures to get your message.

Mute (for 8110 Users) Turns off the microphone of the built-in speakerphone or the handset. Use when you want to confer with someone in the room with you, but you do not want the other party on the call to hear your conversation.

Programmable Dialing Buttons The 12 programmable dialing buttons are provided for one-touch dialing of frequently dialed telephone or account numbers. You can also store emergency numbers, such as 911, or feature access codes on your programmable dialing buttons. **Note:** If you want to store more than 12 programmable dialing numbers, you can use the Switch Feature, "Abbreviated Dialing."

Speakerphone (for 8110 Users) Allows you to place and answer calls without lifting the handset. Use any time you prefer hands-free communication, both speaking and listening or for group conference situations.

Switch Features

Abbreviated Dialing (AD) Allows you to store selected telephone numbers as 3 or fewer digits for quick and easy dialing. Each number can be a complete or partial telephone number, an extension number, or a trunk or feature code. There are 3 possible type of lists — personal, group, and system — and you can have a total of 13 lists. Numbers on a personal list are programmable by you; numbers on group lists are programmable by the controller of the list; system lists are programmable only by the System Manager. Use this feature as a timesaver for dialing frequently called, lengthy, or emergency numbers. **Note:** Check with your System Manager for the types of lists you have and how many of each.

Automatic Callback Sends you a special 3-burst ring tone indicating that a previously busy extension is now available. Use to avoid constant redialing when you want to speak to someone who is frequently busy on the telephone. **Note:** You can use this feature only for extensions, not outside numbers.

Call Forwarding — Busy/Don't Answer Temporarily forwards all your calls to another extension or to the attendant if your telephone is busy or you do not answer your calls within a preset number of rings. Use when you want your calls to be forwarded to a telephone number of your choice.

Call Forwarding — Follow Me Temporarily forwards all your calls to another extension or to an outside number, depending on your system. Use when you want your calls to be automatically forwarded to a telephone number of your choice.

Call Park Puts a call on hold at your telephone, for retrieval at any extension. Use when you need to go elsewhere to get information during a call, or whenever you want to complete a call from a different location. Also, if the call received is for someone else, use it to hold the call until the called party can answer from the nearest available telephone.

Call Pickup Lets you answer a call at your telephone for another extension in your pickup group. Use when you want to handle a call for a group member who is absent or otherwise unable to answer. **Note:** You can use this feature only if you and the called party have been assigned to the same pickup group by your System Manager.

Call Waiting When you are busy on a call, sends a distinctive tone to notify you of another incoming call waiting to be answered. This allows you to complete or hold your present call and pick up the waiting call. It will save you from missing calls, and your waiting caller from having to call back later.

Conference Allows you to add a third party to a call, so that you can conduct a 3-way conversation. (If you want to conference more than 3 parties, call your attendant for assistance.) Use to set up time-saving conferences or to spontaneously include a third party. **Note:** If you have both an active call and a call on hold, you must terminate one of them before you can use Conference.

Hold (with Second Dial Tone) Puts a call in a holding state until you can return to it. While a call is on hold, you can place another call, activate another feature, answer a waiting call, or leave your telephone to do another task. Use when you have a call that you don't want to drop, but have to interrupt briefly to do something else.

Last Number Dialed Automatically redials the last number you dialed, either an extension or an outside number. Available with DEFINITY® Generic 2 and System 85 R2V4 and some R3V3 systems. Check with your System Manager to see if the feature is available in your system.

Leave Word Calling (LWC) Leaves a message for another extension to call you back. The called party will be able to dial the message center, AUDIX, or a covering user to retrieve a short, standard message that gives your name and extension, the date and time you called, and the number of times you called. Use any time you want to have someone call you back; it will help cut down on repeated call attempts.

Priority Calling Allows you to call another extension with a distinctive 3-burst ring to indicate that your call requires immediate attention. Use when you have important or timely information for someone.

Send All Calls Temporarily sends all your calls to the extension of a person designated to answer them when you cannot (perhaps a secretary, receptionist, or AUDIX). Use when you will be away from your desk for awhile, or when you do not want to be interrupted by calls.

Transfer Transfers a call from your telephone to another extension or outside number. Use when your caller needs to speak further with someone else. **Note:** Calls from an outside number to your telephone can be transferred only to an extension, not to another outside number.

How to Use the Features

Many features are available for use with your 8102 and 8110 telephones. The procedures which follow give short, step-by-step instructions for using each feature. For your convenience, features are listed alphabetically.

Special Instructions for General Use

As you operate the features assigned to your telephone, keep in mind the following general rules.

- Follow carefully all the steps listed in the procedure for the particular feature you are using.
- If you receive an intercept tone (high-pitched, alternating high and low tone) while attempting to operate any feature, you have taken too much time to complete a procedural step or have made a dialing error. Hang up, get dial tone, and begin again at Step 1.
- The tone that appears in brackets after a step, such as [dial tone], indicates what you should hear from your handset after successfully performing that step. For a list of tones and their meanings, see the sections titled **Tones and Their Meanings**.
- For directions on filling out the Programmable Dialing Buttons Designation Card, see the procedures for "Programmable Dialing Buttons" under Phone Features in this section.

Quick-Reference Lists

At the end of this guide is a set of quick-reference lists. Use the lists to record your feature and trunk codes, Abbreviated Dialing personal list items, and message and attendant extensions. Once you have completed the lists, remove the page from the booklet (tear along the perforation), and keep the lists near your telephone.

Phone Features

The following features can be used no matter which communications system your 8102 or 8110 telephone is connected to. Remember that you can use the Speakerphone and Mute features *only if* you are using an 8110 telephone. Some 8110 users will also be able to use the Auto Answer feature.

Answering and Placing a Call



Note: If you are using the 8110 telephone, you can place and answer calls *either* by going off-hook (by lifting the handset) or leaving the handset on-hook and by pressing [**SPKR**]. Pressing [**SPKR**] simultaneously activates the built-in microphone so that you can place *and* answer calls without lifting the handset.

If you are using the 8102 telephone, you can connect an external speakerphone to the speakerphone/headset jack on the rear of your telephone. For procedures on answering and placing calls with the adjunct speakerphone, refer to the instructions that came with the equipment.

- To answer a call
- 1 Pick up handset
 - 2 Speak to other party

-
- To answer a call using the speakerphone (for 8110 users)
- 1 When you hear the telephone ring, press [**SPKR**]
 - Red light next to [**SPKR**] goes on
 - 2 Speak to other party

-
- To place a call
- 1 Pickup handset [dial tone]
 - 2 Dial desired number

-
- To place a call using the speakerphone (for 8110 users)
- 1 While on-hook, press [**SPKR**] [dial tone]
 - Red light next to [**SPKR**] goes on
 - 2 Dial desired number

-
- To end a call
- 1 Hang up handset
or
if you are using the speakerphone, press [**SPKR**]
 - Red light next to [**SPKR**] goes off

To have your telephone automatically answer a call

Note: For this feature to operate properly on your switch, your line must be administered as "data restricted." Also, for your information, the Auto Answer button is removable and can be replaced by a flat cap (packed in the box with 8110 terminal). If the button is removed, the Auto Answer feature is disabled.

- 1 While handset is on-hook, press [**AUTO**]
 - Button released to the "up" position
 - Colored area under button will remind you that the Auto Answer feature is active
- 2 When a call comes in, the built-in speakerphone on your telephone is automatically activated
 - Both you and the other party hear a short ring and then a burst of tone to indicate that the call has been answered
 - Red light next to [**SPKR**] goes on
- 3 Speak to caller
- 4 When caller ends the call, 8110 telephone hangs up automatically
or
You can press [**SPKR**] to end the call
 - The 8110 telephone is now ready for next Auto Answer call

To turn off the Auto Answer feature

- 1 Press [**AUTO**]
 - Button reverts to "down" position (you can no longer see the color around the button)

Hold



Note: If you want to place or answer another call or activate another feature while you have a call on hold, you can use the Switch Feature, Hold (with Second Dial Tone). For directions on using this feature, see "Hold (with Second Dial Tone)" under the sections, **Switch Features**.

- To put a call on hold
- 1 Press [**HOLD**]
 - Red light next to button goes on; call is on hold
-

- To return to the held call
- 1 Press [**HOLD**]
or
If you have hung up the handset, pick up handset again from the cradle
 - Red light next to button goes off; you are reconnected to other party

Message



- To retrieve a message when your message light is flashing
- 1 Dial the Message extension number _____
or
Ask your System Manager for local retrieval methods

Mute (for 8110 Users)

To prevent the other party from hearing you (to mute microphone)

- 1 Press [**MUTE**]
 - Red light next to [**MUTE**] goes on
 - Other party cannot hear you
-

To resume talking to the other party (to turn on speakerphone microphone, or handset again)

- 1 Press [**MUTE**]
 - Red light next to [**MUTE**] goes off
- 2 Resume conversation with the other party again)

Programmable Dialing Buttons

The 12 programmable dialing buttons are provided for one-touch dialing of frequently dialed telephone numbers. You can also store emergency numbers, such as 911, and feature codes on these buttons.

Shipped with each telephone is a button designation card on which you can write the names, numbers, or codes stored on each of the Programmable Dialing buttons. Use the procedure directly below to remove the plastic cover on the front of your telephone and place the designation card under it.

Note: You can program up to 20 digits and characters (such as a pause, "#", or "*") on a programmable dialing button. If the number you want to store is longer than 20 digits and characters, you can do one of the following:

- Store up to 20 digits and characters on one button; store the remainder of the digits and characters on a second button. To place a call using these buttons, press the first button; when all of the digits and characters have been dialed, press the second button in the sequence.
- Store up to 20 digits and characters on one button; dial the remainder of the digits and characters manually.

To insert the button designation card on your telephone

- 1 If you are using a new telephone, remove the button designation card from the box in which the telephone was shipped
- 2 In the blank space next to the appropriate Programmable Dialing button, write or type the name or telephone number that you want to store there
- 3 Fold along the perforated edge(s) and detach the card(s) from the sheet
- 4 Remove the plastic cover by placing your finger in the finger slot on the right side of the telephone and lifting up
- 5 Place the designation card on the telephone. Replace the plastic cover over the designation card by fitting the cover's bottom tabs into the slots on the telephone and pressing down, allowing the tabs on the top to snap into place

To program any of the 12 programmable dialing buttons (while on-hook)

- 1 Press [**PROGRAM**] to enter programming mode
 - You hear a low continuous tone while you are in programming mode
- 2 Press programmable dialing button on which you want to store the number
 - Tone is briefly interrupted twice
- 3 Dial number you want to program on the button (up to 20 digits and characters, including [**PAUSE**] and [**FLASH**])
 - The tone to remind you that you are in programming mode is interrupted at each time you press a dial pad key, [**PAUSE**], or [**FLASH**]
 - You hear a rapid error tone if you try to enter more than 20 digits and characters

You can use [**PAUSE**] to program a 5-second pause between a dialing access number (for example, a 9) and the telephone number, and for certain banking and long-distance services. (For example, to put a pause between a dialing access number and the telephone number, press 9, then [**PAUSE**], then 12125551234.)

- 4 To program another programmable dialing button, repeat steps 2 and 3
- 5 Press [**PROGRAM**] when you are ready to exit programming mode

To dial a number with a programmable dialing button

- 1 Pick up handset
or
if you are using an 8110 telephone, you can press [**SPKR**]
- 2 When you hear dial tone, press appropriate programmable dialing button
 - Number programmed on the button is automatically dialed

To erase a number stored on a programmable dialing button

- 1 Press [**PROGRAM**]
- 2 Press button to be cleared *twice*
- 3 Press [**PROGRAM**]

Redial (With Auto-Pause) □

To automatically redial the last number you dialed (from the-dial pad)

- 1 Pick up handset
or
if you are using an 8110 telephone, you can press [**SPKR**] [dial tone]
- 2 Press [**REDIAL**]
 - Number is automatically redialed

Note: You will hear a rapid error tone if the dialed number is longer than 20 elements.

To program an automatic pause for redialed numbers

- 1 While the telephone is on-hook, press [**PROGRAM**] [programming tone]
- 2 Press [**REDIAL**]
- 3 Press the appropriate access code and number of pauses in order to insert a long enough waiting time to obtain a second dial tone.

For example, if you need 2 pauses inserted between the access code, such as "9," and the remainder of the telephone number you are dialing, you would press [**PAUSE**] twice.

Note: You may store up to 3 different access code/pause combinations.

- 4 Press [**PROGRAM**] again

EXAMPLE In the following example, there are 3 different access code/pause combinations.

[programming tone]

Press [**REDIAL**]

- 3 Dial 9 and then press [**PAUSE**] 3 times ([**PAUSE**] [**PAUSE**] [**PAUSE**]). Since each depression of [**PAUSE**] adds 0.5 seconds, 3 depressions of [**PAUSE**] is 1.5 seconds.
- 4 Dial *9 (the second access code needed in the dialing sequence in this example) and then press [**PAUSE**] 2 times ([**PAUSE**] [**PAUSE**])
- 5 Dial *8 (the third access code needed in this sequence and then press [**PAUSE**] 4 times ([**PAUSE**] [**PAUSE**] [**PAUSE**] [**PAUSE**])
- 6 Press [**PROGRAM**] again
 - The access code sequence is stored for redialing at a later time. Now, when you press [**REDIAL**] to redial a call using one of the above access code/pause combinations (for example, 91212555 1234), the telephone will automatically insert the correct number of pauses (3 in this example) to ensure waiting the appropriate length of time to obtain a second dial tone.

To erase *all* stored
access codes

- 1 Press [**PROGRAM**] [programming tone]
- 2 Press [**REDIAL**] *twice*
- 3 Press [**PROGRAM**] again

Speakerphone (for 8110 Users)

To place/answer a call
without lifting the
handset, or to use
speakerphone with any
feature

- 1 Press [**SPKR**]
 - Red light goes on next to button
- 2 Place or answer call, or access selected feature
 - Adjust speakerphone volume with sliding arm on right of set
- 3 Press [**SPKR**] again to hang up
 - Red light goes off

To prevent party from
hearing you (to mute
microphone)

- 1 Press [**MUTE**]
 - Red light next to [**MUTE**] goes on and other party cannot hear you

To resume talking to other party (to turn on speakerphone microphone, or handset again)

- 1 Press [**MUTE**]
 - Red light next to [**MUTE**] goes off
- 2 Resume conversation with other party

To change from speakerphone to handset

- 1 Lift handset and talk
 - Red light next to [**SPKR**] goes off

To change from handset to speakerphone

- 1 During a call using handset, press [**SPKR**]
 - Red light goes on next to [**SPKR**]
- 2 Hang up handset

Switch Features

Since your 8102 or 8110 telephone is connected to a DEFINITY Generic 2 or System 85 communications system, you may be able to use any of the following features. Check with your System Manager to see which of these features have been assigned to your telephone.

Special Instructions

The first time you use these procedures, you will need to customize them for yourself by following the directions below. Your System Manager can supply the information required.

- To the right of each feature name is a box. For each feature that you have, mark a [✓] in the blank box as a reminder. There is already a check in the box beside the Conference, Hold, and Transfer features.
- You can activate or cancel most of the features by dialing 2- or 3-digit code. In the blanks provided within the procedures, write in the assigned feature code numbers. **Note:** You can store these feature codes on Programmable Dialing buttons (including [FLASH]).

Abbreviated Dialing (AD)

Note: Both the 8102 and the 8110 telephones have 12 Programmable Dialing buttons on which you can store telephone numbers or access codes. In addition, DEFINITY Generic 2 and System 85 allow you to store numbers in a maximum of 3 Abbreviated Dialing lists.

To program or reprogram an outside number, extension, or feature code into a personal list

Personal List 1	
Item	Number
1	9-555-4280 (home)
2	ext 6344 (guard)
3	9-919-755-0000 (print shop)
4	*60 (mssg retrieval)

- 1 On a separate sheet of paper, jot down the outside numbers, extensions, and feature codes you want to program as items on your personal list (see example to the left)
Note: Each telephone number or feature code is stored as a separate list item.
- 2 Dial Abbreviated Dialing program code (while off-hook) [confirmation tone]
- 3 Dial personal list code
- 4 Dial desired list item number (for example, 09, 01-95, and so on, depending on list size) [dial tone]
- 5 Dial outside number, extension, or feature code you want to store

- 6 Press [#] [confirmation tone]
 - Number is stored
 - Repeat steps 3 through 6 if you want to program additional items on the same list
- 7 Hang up to end programming
 - If you want to continue programming begin again at step 2 to program another personal list

Note: Record your personal list items on the Abbreviated Dialing list in the back of this guide; group and system lists are available from the controller of the list or from your System Manager.

To place a call using a personal, group, or system list

- 1 Dial appropriate Abbreviated Dialing list code (while off-hook)
 - Personal _____ [dial tone]
 - Group _____ [dial tone]
 - System _____ [dial tone]
- 2 Dial desired list item (1, 2, 3..., 01, 02, 03...)
 - Stored number is automatically dialed

Automatic Callback □

To automatically place another call to an extension that is frequently busy

- 1 Press [**FLASH**] after hearing busy tone [recall dial tone]
- 2 Dial the Automatic Callback code _____ [dial tone]
- 3 Dial extension [confirmation tone]
- 4 Hang up (within 7 seconds)
 - You will receive a 3-burst priority ring when the extension you attempted to call is available
- 5 Lift handset when you hear priority ring [ringback tone]
 - A call is automatically placed to called extension, which receives regular ringing

Note: Only one Automatic Callback call at a time can be placed, and Automatic Callback is canceled after 20 to 40 minutes if the callback call is unanswered.

To cancel Automatic
Callback

- 1 Dial Automatic Callback cancel code (while off-hook)
_____ [confirmation tone]

Call Forwarding — Busy/Don't Answer ■

To activate Call
Forwarding —
Busy/Don't Answer

- 1 Dial Call Forwarding — Busy/Don't Answer code
(while off-hook) _____ [dial tone]
- 2 Dial extension where calls will be sent
_____ [confirmation tone]

Note: If you hear intercept tone, you are attempting to forward your calls to a restricted telephone, a telephone with Call Forwarding — Follow Me activated, or a telephone in another partition or group (if you are in a tenant services environment). See your System Manager for more information.

- 3 Hang up

To cancel Call
Forwarding —
Busy/Don't Answer

- 1 Dial Call Forward cancel code (while off-hook) _____
_____ [confirmation tone]
- 2 Hang Up
 - Your calls will ring at your own voice terminal again

To temporarily redirect all calls to an extension or outside number of your choice

- 1 Dial Call Forwarding — Follow Me code (while off-hook) _____ [dial tone]
- 2 Dial extension or number where calls will be sent [confirmation tone]

Note: You may hear a half ring for each call forwarded after you have activated this feature and hung up. Also, some voice terminals may have restrictions on where calls can be forwarded (only on DEFINITY Generic 2 and System 85 R2V4 and later releases); see your System Manager.

To cancel Call Forwarding — Follow Me

- 1 Dial Call Forward cancel code (while off-hook) _____ [confirmation tone]
- 2 Hang up
 - Your calls will ring at your own voice terminal again

Call Park

To park a call (for retrieval at any extension)

- 1 Press [**FLASH**] [recall dial tone]
 - Second party is temporarily put on hold
- 2 Dial Call Park trunk code _____ [dial tone]
- 3 Dial the Call Park zone number [confirmation tone]
- 4 Dial an idle answer-back channel number [confirmation tone]
- 5 Hang up
 - Held party is transferred to the answer-back channel and hears ringback tone (or music) while waiting

To retrieve parked call from any extension

- 1 Dial Call Park answer-back code _____ [dial tone]
- 2 Dial channel number where call was parked against [confirmation tone]

Note: If you receive intercept tone, parked call has been disconnected or retrieved by another party.

Call Pickup

To answer a call to a member of your pickup group when your voice terminal is idle

- 1 Dial Call Pickup code (while off-hook) _____
 - You are connected to ringing call

To answer a call to your pickup group while on another call

- 1 Press [**FLASH**] _____ [recall dial tone]
 - Present call put on hold
- 2 Dial Call Pickup code _____
 - Called voice terminal stops ringing
 - You are connected to ringing call

To return to a held call

- 1 Complete present call and hang up
 - Held call sends a 3-burst priority ring
- 2 Lift handset
 - You are connected to held call

Call Waiting

To answer a call
waiting tone

- 1 Complete present call and hang up [ringing]
 - Receive ringing from waiting call (1—internal, 2—outside, 3—priority)
 - 2 Pick up and answer
-

To answer a call
waiting tone, putting
present call on hold

- 1 Press [**FLASH**] [recall dial tone]
 - Present call put on hold
 - 2 Dial Call Waiting answer/hold code _____
 - You are connected to waiting call
-

To return to held call

- 1 Complete present call and hang up
 - Held call sends 3-burst priority ring
- 2 Lift handset
 - You are connected to held call

Conference

To add a third party to
a call

- 1 Press [**FLASH**] [recall dial tone]
 - Present call temporarily put on hold
 - 2 Dial number of third party and wait for answer

Note: You can privately discuss the call with the third party at this time; if no answer or busy, press [**FLASH**] twice to return to the original party.
 - 3 Press [**FLASH**]
 - All parties now connected
-

To drop a third party

- 1 Press [**FLASH**]
 - You remain connected to original party



- To put a call on soft hold
- 1 Press [**FLASH**] [recall dial tone]
 - 2 Dial Hold code _____ [dial tone]
- Note:** If you hang up, held call sends a 3-burst priority ring.
-

- To return to a held call
- 1 Hang up, receive 3-burst priority ring, and lift handset
-

- To put a call on hold and place call 2
- 1 Press [**FLASH**] [recall dial tone]
 - 2 Dial Hold code _____ [dial tone]
 - Call 1 is put on hold
 - 3 Dial call 2 (or another feature)
- Note:** If you hang up, call 1 sends a 3-burst priority ring.
-

- To put call 2 on hold and return to call 1
- 1 Press [**FLASH**] [recall dial tone]
 - 2 Dial Hold code _____
 - Call 2 is put on hold, and call 1 is reconnected
- Note:** If you hang up, call 2 sends a 3-burst priority ring.

Last Number Dialed

To automatically redial the last number you dialed (extension outside number, or trunk/feature code)

1 Dial Last Number Dialed code (while off-hook) _____

- Number is automatically dialed (up to 20 digits)

Note: Available with DEFINITY Generic 2 and System 85 R2V4 and some R2V3 systems. Check with your System Manager to learn if the feature is available on your system.

Limitations on this feature should be noted. Digits dialed via Abbreviate Dialing feature dial codes, authorization codes, and Station Message Detail Recording (SMDR) account codes are NOT retained in memory and must be redialed for each call.

Leave Word Calling (LWC)

To leave a message *after* dialing an extension (when call is not answered, you hear a coverage or busy tone, or you have been put on hold)

- 1 Press [**FLASH**] [recall dial tone]
- 2 Dial Leave Word Calling code _____ [dial tone]
- 3 Dial extension

- Message light on called voice terminal goes on (if so equipped) [confirmation tone]

Note: If reorder tone is heard, message is not stored; try again.

To leave a message without ringing an extension

- 1 Did Leave Word Calling code _____ [dial tone]
- 2 Dial extension [confirmation tone]
- Message light on called voice terminal goes on (if so equipped)
- 3 Hang up

To cancel a Leave
word calling message
(you cannot cancel
messages for an
AUDIX Subscriber)

- 1 Dial Leave Word Calling cancel code (while off-hook) _____ [dial tone]
- 2 Dial extension _____ [confirmation tone]
 - Message is deleted

Note: If reorder tone is heard, message is not deleted;
try again.

Priority Calling

To place a priority call
(3-burst ring)

- 1 Dial Priority Calling code (while off-hook) _____ [dial tone]
- 2 Dial extension _____

To send all incoming calls (except priority, intercom and personal office calls) immediately to an assigned extension, AUDIX or message center for coverage

- 1 Dial Send All Calls code _____ [confirmation tone]

Note: You may hear a half ring as each call is sent to coverage if you have a DEFINITY Generic 2 or System 85 R2V4.

To cancel Send All Calls

- 1 Dial Send All Calls cancel code _____ [confirmation tone]

- Your calls ring at your own voice terminal again

Transfer



To send present call to another extension or outside number

- 1 Press [**FLASH**] [recall dial tone]
 - Present call put on hold
- 2 Dial extension or number to which the call is to be transferred [ringback tone]
 - Remain on the line and announce call if desired; if no answer or number dialed is busy, return to held call by pressing [**FLASH**] twice
- 4 Hang up
 - Call is sent to the dialed extension or number

Tones and Their Meanings

Ringling tones are produced by an incoming call. Feedback tones are those that you hear through the handset (receiver) or the speaker, if you have one.

Ringling Tones

- **1 ring** — A call from another extension.
 - **2 rings** — A call from outside or from the attendant.
 - **3 rings** — A priority call from another extension or a call from an Automatic Callback call that you placed.
 - **half ring** — A call redirected from your voice terminal to another because Send All Calls or Call Forwarding — Follow Me is active.
-

Feedback Tones

- **busy tone** — A low-pitched tone repeated 60 times a minute; indicates that the number dialed is in use.
- **call-waiting ringback tone** — A ringback tone with a lower-pitched signal at the end; indicates that the extension called is busy, but the called party has been given a call-waiting tone.
- **call-waiting tone** — 1, 2, or 3 beeps of high-pitched tone, not repeated; indicates that an incoming call is waiting to be answered. Number of beeps designates the source: 1 for an internal call, 2 for an outside or attendant call, 3 for a priority call.
- **confirmation tone** — 3 short bursts of tone; indicates that a feature activation or cancellation has been accepted.
- **coverage tone** — 1 long burst of tone; indicates that your call will be sent to another extension to be answered by a covering user.
- **dial tone** — A continuous tone; indicates that dialing can begin.
- **intercept/time-out tone** — An alternating high and low tone; indicates a dialing error, a denial of the requested service, or a failure to dial within a preset interval (usually 10 seconds) after lifting the handset or dialing the previous digit.
- **recall dial tone** — 3 short bursts of tone followed by a steady dial tone; indicates that the feature request has been accepted and can begin.
- **reorder tone** — A fast-busy tone repeated 120 times a minute; indicates that all trunks are busy.
- **ringback tone** — A low-pitched tone repeated 15 times a minute; indicates that the number dialed is being rung.

Key Words to Know

access code See **feature code**.

activate To begin or turn on the operation of a feature.

attendant The person who handles incoming and outgoing calls at the main telephone console.

AUDIX Audio Information Exchange, an optional voice mail and message service that provides coverage for calls to you by recording callers' messages and reporting Leave Word Calling messages.

coverage Automatic redirection of calls from an unanswered voice terminal to another voice terminal or answering service. Redirection could be to the extension of a receptionist, secretary, coworker, AUDIX or message center. A person who provides coverage is a covering user.

DEFINITY® Communications System Generic 2 The AT&T switch to which you may be connected. It transmits and receives voice and data signals for all communications equipment in your network. (See also System 85.)

dial pad The 12 pushbuttons you use to dial a number and access features.

extension A dialing number of 3 to 5 digits assigned to each voice terminal connected to your DEFINITY® Generic 2 or your System 85.

feature A special function or service, such as Conference, Hold, and Send All Calls.

feature code A dial code of 1, 2, or 3 digits (4 digits in System 85 R2V4), that you use to activate or cancel the operation of a feature.

group list One of the 3 types of Abbreviated Dialing lists; programmable by the System Manager or a controller of the list. Contains telephone numbers useful to members of a specific group, and stored as 1- or 2-digit list item, depending on the number of members in the list.

handset The hand-held part of the voice terminal that you pick up, talk into, and listen from. Also known as the receiver.

off-hook When the handset is removed from the cradle (for example, when you lift the handset to place or answer a call) or speakerphone is ON.

on-hook When the handset is left on the cradle or speakerphone is OFF.

party A person who places or answers a call.

personal list One of the 3 types of Abbreviated Dialing lists; programmable by the System Manager or by you, the user. Contains telephone numbers of your choice, and stores each of them as a 1- or 2-digit list item, depending on the number of members in the list.

personal list item One of the slots on an Abbreviated Dialing personal list.

phone features Those telephone features that you can use immediately no matter which communications system your telephone is connected to.

pickup group A group of telephone users who can answer calls for each other through the Call Pickup feature. Group members are determined by the System Manager and are usually located in the same work area or perform similar job functions.

priority call An important or urgent call that sends a special 3-burst ring and does not redirect to coverage or forward to designated alternative number.

retrieve To collect telephone messages using your local retrieval methods. (Also, with Call Park, to resume a call from an extension other than the one where the call was first placed or received.)

ringer The device that produces the electronic ringing sound in your voice terminal.

stored number A telephone number that has been programmed and stored as a 1-, 2-, 3-, or 4-digit list item for use with Abbreviated Dialing. It can be a complete or partial telephone number, an extension number, or a trunk or feature code. Once programmed, a number can be accessed by first dialing the list, then the list item digit(s) under which it is stored.

switch The device that makes connections for all voice and data calls for a network, and also contains software for features. Also known as a system switching system, or PBX (private branch exchange). Your switch is an AT&T DEFINITY® Communications System Generic 2 or an AT&T System 85.

switch features Those features that you can use only if your telephone is connected to a System 75 or DEFINITY Generic 1 switching system.

System 85 The AT&T switch to which you may be connected. It transmits and receives voice and data signals for all communications equipment in your network. (See also DEFINITY® Communications System Generic 2.)

system list One of the 3 types of Abbreviated Dialing lists; programmable only by the System Manager. Contains telephone numbers helpful to all system users.

System Manager The person responsible for specifying and managing the operation of features for all the voice and data equipment in your network.

trunk A telecommunications channel between your switch and the local or long-distance calling network or to another switch. Trunks of the same kind connecting to the same endpoints are assigned to the same trunk group.

trunk code A dial code of up to 4 digits that you dial to access a trunk group to place an outside call.

voice terminal A telephone equipped with an array of specially designed features (for example, administrable buttons) and functional capabilities that distinguish it from a conventional telephone.

Quick-Reference Lists

Feature Codes	
Feature	Code
ABBREVIATED DIALING Personal	
Group	
System	
Program	
AUTOMATIC CALLBACK	
Cancel	
CALL FORWARDING — BUSY/DON'T ANSWER	
Cancel	
CALL FORWARDING — FOLLOW ME	
Cancel	

Feature	Code
CALL PARK	
Answer Back	
CALL PICKUP	
CALL WAITING	
HOLD	
LAST NUMBER DIALED	
LEAVE WORD CALLING	
Cancel	
PRIORITY CALLING	
SEND ALL CALLS	
Cancel	